

Smart Card Hotel Door Safety Lock SL-H1068E



1, Features:

- Certification:CE,FCC,Rohs
- Lock Class: Level C
- Material: hotels, schools, offices, etc.
- Applicable door type: wooden door anti-theft door wang li gate compound door
- Unlock mode: swipe card\mechanical key
- Applicable door thickness:35-110MM
- Panel size: 350*80X20MM
- Feature:anti-smash, anti-pull, anti-saw, anti-theft, automatic lock
- Color:Gold, Silver,Red Bronze, Black
- Low Power Alarm: Low Light Indication
- Safety feature: lock on, lock inside

2, Specification:

Material	Inner steel plate Outer Titanium-aluminium alloy
Mortise	Standard:240*24mm lock Mortise
Door Type	Wooden door, composite door
Power supply	6V (4x AA batteries)
Unlock method	swipe + key
Low voltage worming	Yes
Card reading distance	less than 3CM
Color:	gray / gold / silver
Application:	hotel / school / office/apartment, etc.
Door thickness:	30-55mm
Software	Yes
Type	Hotel management software
OS	Windows XP/Vista
Card Type	Mifare Card/ T555 / EM430 / apartment ID board
Card reader	Hotel lock encoder
Environment & Verification	
Working Temperature	-20°C-50°C
Working Humidity	20%-70%
Backup unlock mechanism	Mechanical Key
Dimension (L*W)	350x80x20mm
Warranty:	2 year
Weight:	3KG
Battery life	support 5000 lockout unlocking operation

3, Lock Mortise:

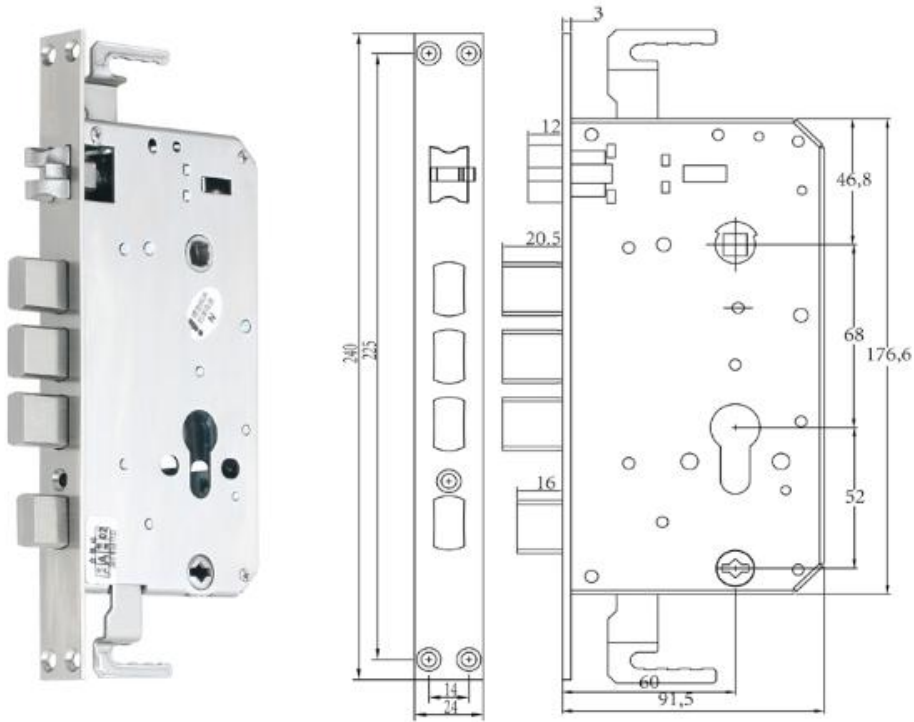

6, Packing Details



1: Front panel; 2: Real panel

3: Lock mortise; 4: Lock strike box

5: Lock strike plate

6: Room card

7: Mechanical lock cylinder

8: Fix mounting screws

9: Mechanical key

5, Installation Drawing

